

PERFORMANCE
MADE
SMARTER

Product manual

2255

f/I - f/f converter



EAC

UK
CA

CE

TEMPERATURE | I.S. INTERFACES | COMMUNICATION INTERFACES | MULTIFUNCTIONAL | ISOLATION | DISPLAY

No. 2255V103-UK
From serial no.: 191356001

PR
electronics

6 Product Pillars

to meet your every need

Individually outstanding, unrivalled in combination

With our innovative, patented technologies, we make signal conditioning smarter and simpler. Our portfolio is composed of six product areas, where we offer a wide range of analog and digital devices covering over a thousand applications in industrial and factory automation. All our products comply with or surpass the highest industry standards, ensuring reliability in even the harshest of environments and have a 5-year warranty for greater peace of mind.

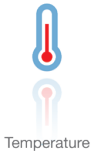

Our range of temperature transmitters and sensors provides the highest level of signal integrity from the measurement point to your control system. You can convert industrial process temperature signals to analog, bus or digital communications using a highly reliable point-to-point solution with a fast response time, automatic self-calibration, sensor error detection, low drift, and top EMC performance in any environment.



We deliver the safest signals by validating our products against the toughest safety standards. Through our commitment to innovation, we have made pioneering achievements in developing I.S. interfaces with SIL 2 Full Assessment that are both efficient and cost-effective. Our comprehensive range of analog and digital intrinsically safe isolation barriers offers multifunctional inputs and outputs, making PR an easy-to-implement site standard. Our backplanes further simplify large installations and provide seamless integration to standard DCS systems.



We provide inexpensive, easy-to-use, future-ready communication interfaces that can access your PR installed base of products. All the interfaces are detachable, have a built-in display for readout of process values and diagnostics, and can be configured via push-buttons. Product specific functionality includes communication via Modbus and Bluetooth and remote access using our PR Process Supervisor (PPS) application, available for iOS and Android.



Our unique range of single devices covering multiple applications is easily deployable as your site standard. Having one variant that applies to a broad range of applications can reduce your installation time and training, and greatly simplify spare parts management at your facilities. Our devices are designed for long-term signal accuracy, low power consumption, immunity to electrical noise and simple programming.



Our compact, fast, high-quality 6 mm isolators are based on microprocessor technology to provide exceptional performance and EMC-immunity for dedicated applications at a very low total cost of ownership. They can be stacked both vertically and horizontally with no air gap separation between units required.



Our display range is characterized by its flexibility and stability. The devices meet nearly every demand for display readout of process signals and have universal input and power supply capabilities. They provide a real-time measurement of your process value no matter the industry and are engineered to provide a user-friendly and reliable relay of information, even in demanding environments.

f/I - f/f converter

2255

Table of contents

Warning	4
Symbol identification	4
Safety instructions	5
How to dismantle system 2200	6
Technical characteristics	7
Input	7
Output(s)	7
Electrical specifications	8
Order	11
Block diagram	11
Analog output programming by way of jumpers	11
Programming / operating the function keys	12
Routing diagram: f/I converter with analogue and digital output	13
Setting of f/i converter with analogue and digital output	14
Routing diagram: f/f converter for pulse	17
Setting of f/f converter to pulse division / multiplication	18
Routing diagram: Frequency generator	20
Setting of frequency generator	21
Document history	23

Warning



GENERAL

This device is designed for connection to hazardous electric voltages. Ignoring this warning can result in severe personal injury or mechanical damage. To avoid the risk of electric shock and fire, the safety instructions of this manual must be observed and the guidelines followed. The specifications must not be exceeded, and the device must only be applied as described in the following. Prior to the commissioning of the device, this manual must be examined carefully. Only qualified personnel (technicians) should install this device. If the equipment is used in a manner not specified by the manufacturer, the protection provided by the equipment may be impaired.



**HAZARD-
OUS
VOLTAGE**

Warning

Until the device is fixed, do not connect hazardous voltages to the device. The following operations should only be carried out on a disconnected device and under ESD-safe conditions:

- Dismantlement of the device for setting of DIP switches and jumpers.
- General mounting, wire connection and disconnection.
- Troubleshooting the device.



Repair of the device and replacement of circuit breakers must be done by PR electronics A/S only.



**INSTAL-
LATION**

Warning

To keep the safety distances, devices with two built-in relays must not be connected to both hazardous and non-hazardous voltages on the same device's relay contacts. SYSTEM 2200 must be mounted in socket type S3B Releco (order no 7023).

Symbol identification



Triangle with an exclamation mark: Read the manual before installation and commissioning of the device in order to avoid incidents that could lead to personal injury or mechanical damage. Warning / demand. Potentially lethal situations.



The CE mark proves the compliance of the device with the essential requirements of the EU directives.



The UKCA mark proves the compliance of the device with the essential requirements of the UK regulations.



The double insulation symbol shows that the device is protected by double or reinforced insulation.

Safety instructions

Definitions

Hazardous voltages have been defined as the ranges: 75 to 1500 Volt DC, and 50 to 1000 Volt AC.

Technicians are qualified persons educated or trained to mount, operate, and also trouble-shoot technically correct and in accordance with safety regulations.

Operators, being familiar with the contents of this manual, adjust and operate the knobs or potentiometers during normal operation.

Receipt and unpacking

Unpack the device without damaging it and check whether the device type corresponds to the one ordered. The packing should always follow the device until this has been permanently mounted.

Environment

Avoid direct sun light, dust, high temperatures, mechanical vibrations and shock, and rain and heavy moisture. If necessary, heating in excess of the stated limits for ambient temperatures should be avoided by way of ventilation.

The device must be installed in pollution degree 2 or better.

The device is designed to be safe up to an altitude of 2 000 m.

The device is designed for indoor use.

Mounting

Only technicians, who are familiar with the technical terms, warnings, and instructions in the manual and who are able to follow these, should connect the device. Should there be any doubt as to the correct handling of the device, please contact your local distributor or, alternatively,

PR electronics A/S
www.prelectronics.com

Mounting and connection of the device should comply with national legislation for mounting of electric materials, i.e. wire cross section, protective fuse, and location.

Descriptions of input / output and supply connections are shown in the block diagram and side label.

The following apply to fixed hazardous voltages-connected devices:

The max. size of the protective fuse is 10 A and, together with a power switch, it should be easily accessible and close to the device. The power switch should be marked with a label telling it will switch off the voltage to the device.

Year of manufacture can be taken from the first two digits in the serial number.

Calibration and adjustment

During calibration and adjustment, the measuring and connection of external voltages must be carried out according to the specifications of this manual. The technician must use tools and instruments that are safe to use.

Normal operation

Operators are only allowed to adjust and operate devices that are safely fixed in panels, etc., thus avoiding the danger of personal injury and damage. This means there is no electrical shock hazard, and the device is easily accessible.

Cleaning

When disconnected, the device may be cleaned with a cloth moistened with distilled water.

Liability

To the extent the instructions in this manual are not strictly observed, the customer cannot advance a demand against PR electronics A/S that would otherwise exist according to the concluded sales agreement.

How to dismantle system 2200

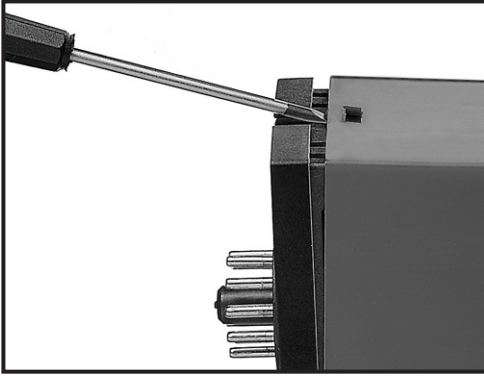

Picture 1:

The back panel of the module is detached from the housing by way of a screwdriver.

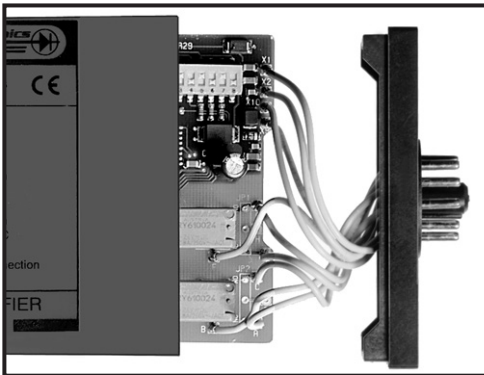

Picture 2:

After this, the back panel can be pulled out together with the PCB, but please notice the position of the PCB as there is a number of different positions in the house. Do not pull the wires unnecessarily, instead pull the PCB.

Switches and jumpers can now be moved.

When assembling the back plate and housing, please make sure no wires are stuck.

f/I - f/f converter 2255

- Programmable f/I converter
- Programmable decimal divider / decimal multiplier
- Programmable frequency generator
- Relay output as option
- Supply voltage 24 VDC

General

The 2255 f/I - f/f converter is configured to the requested function by means of a menu-driven dialog with keys and display in the front. Typical signalling device may be pulse generators e.g. flow meters, tacho-generators or inductive sensors.

The **f/I function** is used for frequency to current / voltage conversion within the frequency range from 0.001 Hz to 20 kHz and for speed control with the digital output as frequency watch.

The **f/f function** is used for division or multiplication of pulses and as a buffer for fast pulse trains.

Max. input frequency 20 kHz.

Max. output frequency 1 kHz.

The **frequency generator function** is for instance used as a time base or a clock generator. Max. output frequency 20 kHz. The 2255 can be delivered pre-configured according to specifications.

Technical characteristics

Input

Programmable input for connexion of standard pulse generator. Input filter may be selected for pulse width > 0.02 ms/max. 20 kHz, or > 10 ms/max. 50 Hz. By contact input, the filter for 10 ms/50 Hz should be used.

Auxiliary supplies

(selected by input configuration)

NAMUR supply: 8 VDC \pm 0.5 V / 8 mA for supply of NAMUR sensors.

SO Supply: 15 VDC. I_{max.} 25 mA. I_{min.} (800 Ω load) 10 mA.

Special supply: As option special voltage supplies within the range 5...15 VDC / 30 mA.

Output(s)

Standard current output (pin 3) programmable within the range 0...20 mA.

Min. span 5 mA. Max. span 20 mA.

Max. offset of 50% of the max. value.

Current limit: Max. 26 mA.

Standard voltage output (pin 2) is obtained by leading the current signal through an internal shunt resistor.

With internal dipswitches a 50 Ω or a 500 Ω shunt resistor is selected, which results in a voltage output of 0...250 mV and 0 / 0.2...1 V (50 Ω) and 0...2.5 V and 0 / 2...10 V (500 Ω).

With a special internal shunt resistor, units with other output voltages can be delivered (max. 12 VDC).

Current and voltage signals are referring to the supply gnd. but if both signals are used simultaneously, only the voltage signal has gnd. as reference.

NPN pulse output (option) for relay, electromechanical counter or equivalent load. The output is current-limited to 130 mA with a PTC resistor.

The **relay output** (option) with change-over contact. 300 VA, max. 150 VRMS, 2 A.

Status indication

Z255 is equipped with 3 status indicators in the front.

- f in: Indicates active input (inactive by the NPN input).
Input frequencies > 50 Hz are shown by fixed light.
- Dig. out: Indicates active output.
- Error: Indicates sensor error by NAMUR input.

Electrical specifications

Environmental conditions

Operating temperature	-20 to +60°C
Calibration temperature	20...28°C
Relative air humidity	< 95% RH (non-cond.)
Protection degree	IP50

Mechanical specifications

Dimensions (HxWxD) (D is excl. pins)	80.5 x 35.5 x 84.5 mm
Weight	125 g

Common specifications

Supply voltage	19.2...28.8 VDC
Internal consumption	2.4 W
Isolation, test / operation	1400 VAC / 150 VAC
Warm-up time	1 min.
Signal / noise ratio	Min. 60 dB
Signal dynamics, output	16 bit
Response time (programmable)	60 ms to 999 s + period time
Temperature coefficient	< ±0.01% of span / °C
Linearity error	≤ ±0.1% of span
Effect of supply voltage change	< 0.005% of span / VDC

Auxiliary voltages:

NAMUR supply	8 VDC ±0.5 VDC / 8 mA
S0 supply	15 VDC / 25 mA
Special (acc. to order)	5...15 VDC / 30 mA
Immunity influence	< ±0.5%

Input

General

Measurement range	0...20 kHz
Min. measurement range	0.001 Hz
Low cut off	0.001 Hz
Max. offset	90% of selec. max. value
Min. pulse width	25 µs

NAMUR input

Trig-level LOW	≤ 1.2 mA
Trig-level HIGH	≥ 2.1 mA
Input impedance	1000 Ω

Sensor error detection

Short-circuit	≥ 7.0 mA
Breakage	≤ 0.2 mA
Response time	≤ 400 ms

Tacho input

Trig-level LOW	≤ 100 mV
Trig-level HIGH	≥ 200 mV
Input impedance	≥ 100 kΩ
Max. input voltage	80 VAC pp

NPN / PNP input

Trig-level LOW	≤ 4.0 V
Trig-level HIGH	≥ 7.0 V
Input impedance	Typ. 3.48 kΩ

TTL input

Trig-level LOW	≤ 1.2 VDC
Trig-level HIGH	≥ 1.7 VDC
Input impedance	100 kΩ

S0 input

Trig-level LOW	≤ 4.5 mA
Trig-level HIGH	≤ 6.2 mA

Analog output**Current output**

Signal range	0...20 mA
Min. signal range	5 mA
Max. offset	50% of selec. max. value
Updating time	20 ms
Load (max.)	20 mA / 600 Ω / 12 VDC
Load stability	< ±0.01% of span/100 Ω

Voltage output through internal shunt

Signal range	0...10 VDC
Min. signal range	250 mV
Max. offset	50% of selec. max. value
Load (min.)	500 kΩ

NPN output

Max. current	130 mA
Max. voltage	28 VD

f/f converter output

Signal range	0...1000 Hz
Min. pulse width	500 μs
Max. pulse width	999 ms
Max. duty cycle	50%

Frequency generator

Pulse width	
f < 50 Hz	Min. 10 ms, max. 999 s
f ≥ 50 Hz	50% duty cycle

Relay output

Max. frequency	20 Hz
Max. voltage	150 VAC / VDC
Max. AC current	2 A
Max. AC power	300 VA
Max. DC current, resistive load:	
@ U _{relay} ≤ 30 VDC	2 ADC
@ U _{relay} > 30 VDC	[1380 × U _{relay} ⁻² × 1.0085 ^{U_{relay}}] ADC

Graphic depiction of $[1380 \times U_{\text{relay}}^{-2} \times 1.0085^{U_{\text{relay}}}]$:

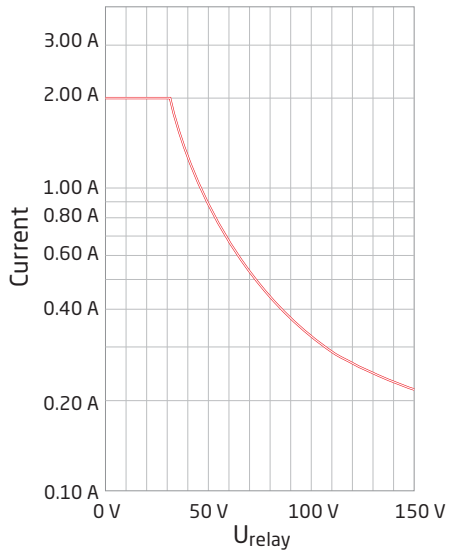

Observed authority requirements

EMC	2014/30/EU & UK SI 2016/1091
LVD	2014/35/EU & UK SI 2016/1101
RoHS	2011/65/EU & UK SI 2012/3032
EAC	TR-CU 020/2011

Of span = Of the presently selected range

Order

Type	Version	Output
2255	Programmable : B	Analog + NPN output : 1
		Analog + relay output : 2

Block diagram

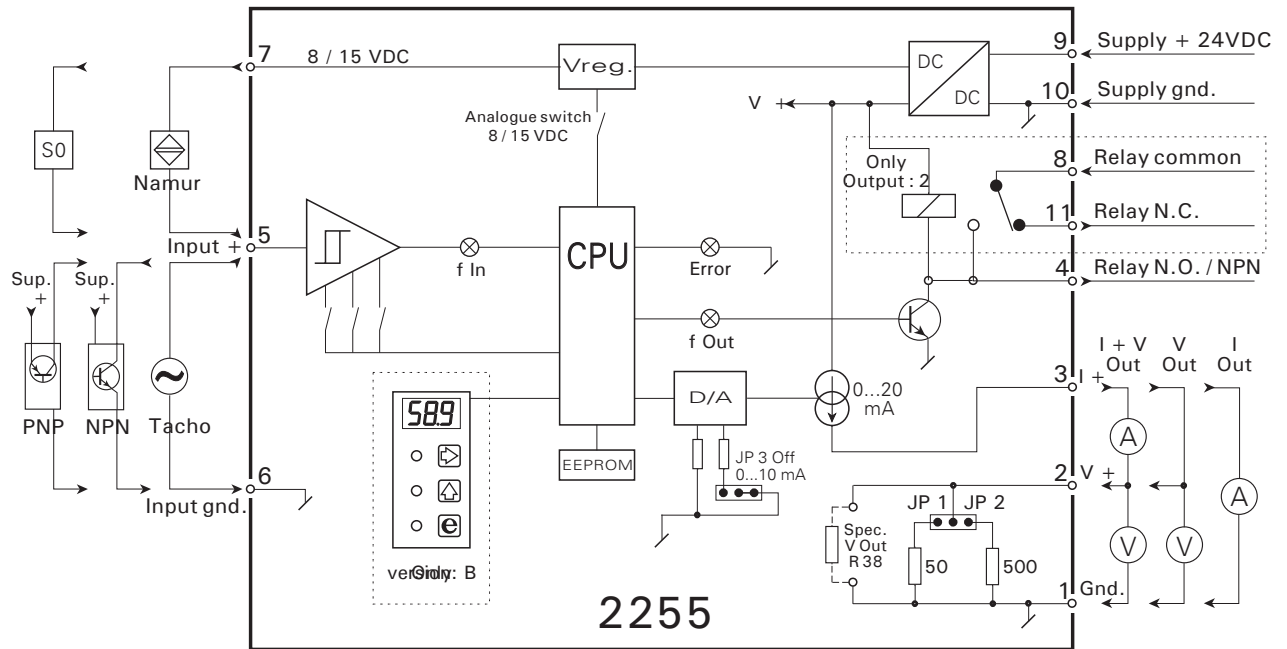

Analog output programming by way of jumpers

Output range	JP3	JP2	JP1
0...10 mA (current only)	OFF	-	-
0...20 mA (current only)	ON	-	-
0...10 mA / 0...0.5 V	OFF	OFF	ON
0...20 mA / 0...1.0 V	ON	OFF	ON
0...10 mA / 0...5.0 V	OFF	ON	OFF
0...20 mA / 0...10.0 V	ON	ON	OFF
Special voltage output: (Resistor R38 mounted)	ON or OFF	OFF	OFF

Programming / operating the function keys

Documentation for routing diagram

The programming is menu-controlled. The main menus are numbered in level 0 (x.0), and the submenus are numbered in level 1 (x.1 to x.5). Each submenu has an accompanying entry menu. The menus are structured in such a way that the menus most frequently used are closer to the default menu 0.0. Please note that programming is only possible when submenu 5.4 PAS has the value 040.

Main, sub-, and entry menus are selected by the 3 function keys **▶**, **◀** and **Ⓞ** as outlined in the routing diagram.

Activating **Ⓞ** in the submenus will display the current value of the entry and parameter selection menus.

In entry menus, the digit that can be changed will flash.

Active digit position is shifted by the **◀▶** key, and the value is changed by the **▲** key.

When the decimal point flashes, its position can be changed by the **◀▶** key.

In entry menus with fixed parameters, you switch between the parameters by the **◀▶** key.

Save by first activating **▶** and then **▲** simultaneously.

To return to the previous menu without changing the parameters, activate **Ⓞ**.

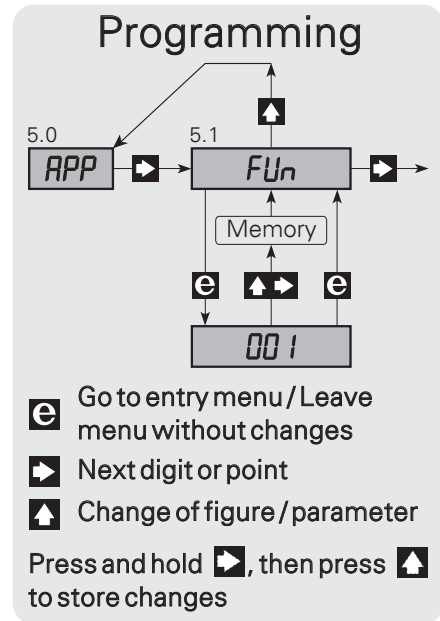

Routing diagram

for

f / I converter with analogue and digital output [Function no. 001]

Power On At power ON, or if no keys have been activated for a period of 2 minutes, the display returns to main menu 0.0

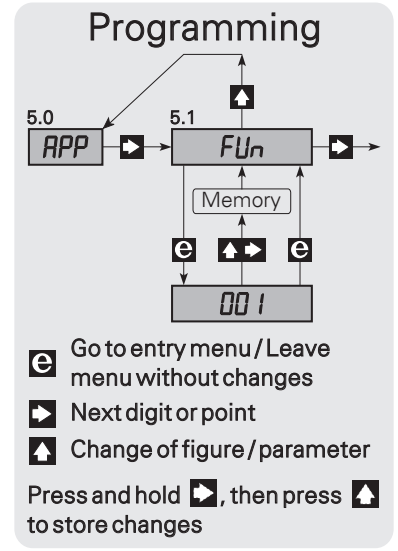
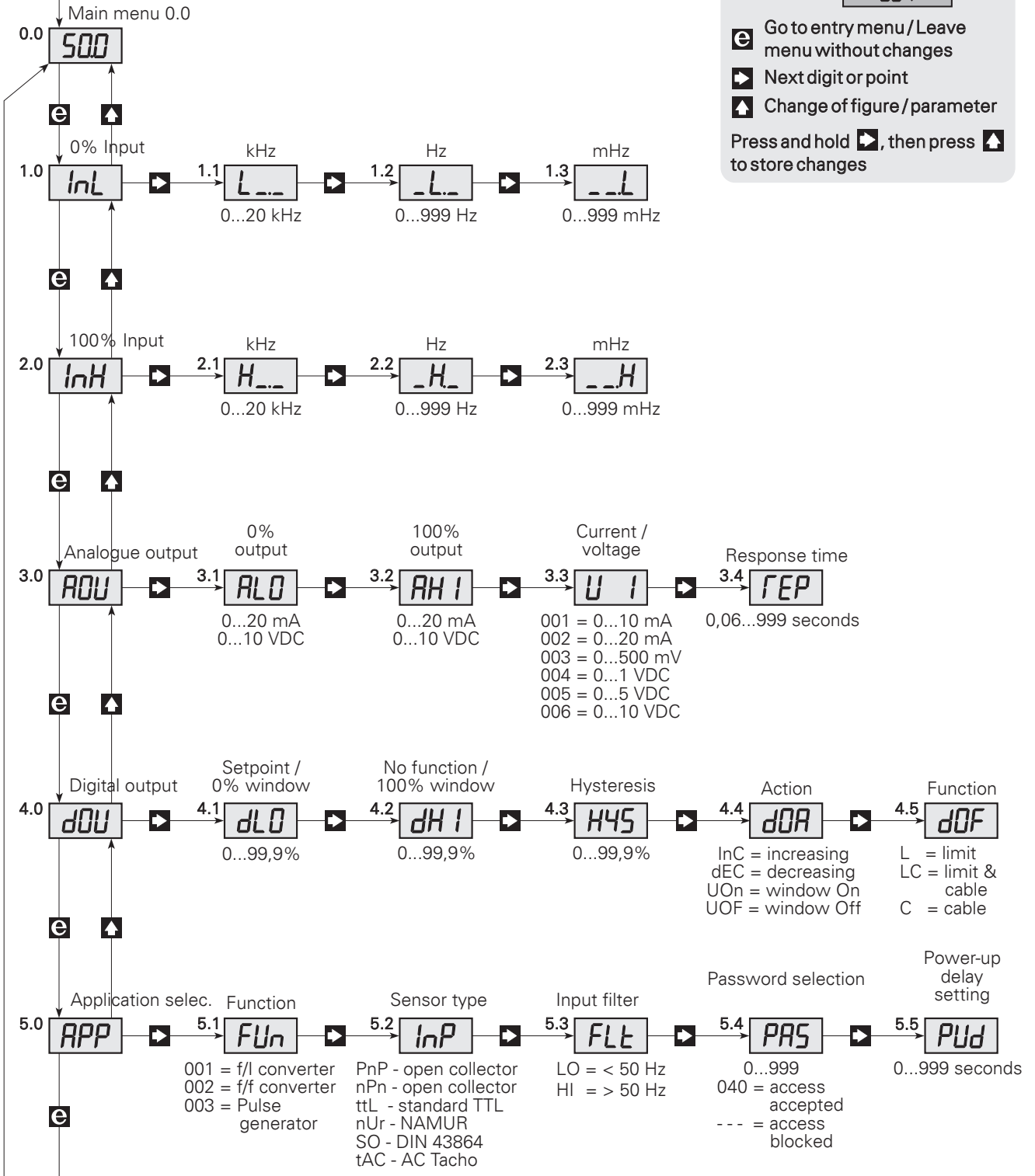

Setting of f/i converter with analogue and digital output

The following describes the routing diagram menu points from 0.0 to 5.5 for setting the f/i converter with analogue and digital output.

Example:

Frequency span	0...12550.5 Hz
Analogue output	4...20 mA
Response time	2.5 s
Alarm frequencies	< 1000 Hz, > 11000 Hz (alarm window)
Hysteresis	20 Hz
Digital output action	Active within the alarm window
Digital output function	Trip amplifier and sensor fault alarm
Sensor	NAMUR
Input filter	Pulse width > 0.02 ms
Digital output power up delay	10.0 s

First, the function f/i converter must be chosen in submenu 5.1.

0.0 DEFAULT - The input frequency is displayed in % of the input span.

At power ON, or if no keys have been activated for a period of 2 minutes, the display returns to default. When the display is in default, menu 0.0 activating the key 1 will indicate the present function, i.a. F01.

1.0 InL - Setting of 0% frequency.

1.1 L.- 0% setting of frequency in kHz.
Entering of example = 000.
Valid selections are 0...20.0 kHz.

1.2 -L.- 0% setting of frequency in Hz.

Entering of example = 000.
Valid selections are 0...999 Hz.

1.3 -L 0% setting of frequency in mHz.

Entering of example = 000.
Valid selections are 0...999 mHz.

2.0 InH - Setting of 100% frequency.

2.1 H.- 100% setting of frequency in kHz.

Entering of example = 012.
Valid selections are 0...20.0 kHz.

2.2 -H.- 100% setting of frequency in Hz.

Entering of example = 550.
Valid selections are 0...999 Hz.

2.3 -H 100% setting of frequency in mHz.

Entering of example = 500.
Valid selections are 0...999 mHz.

3.0 AOU - Setting of analogue output.

3.1 ALO - 0% setting of analogue output

Entering of example = 04.0.
Valid selections are current 0.0...20.0 mA or voltage 0.0...10 VDC.

3.2 AHI - 100% setting of analogue output

Entering of example = 20.0.
Valid selections are current 0.0...20.0 mA or voltage 0.0...10 VDC.

3.3 UI - Current or voltage output setting.

NB: Please see jumper positioning in "Programming of analogue output".

Entering of example = 002.

Possible selections are:

001 = current output 0...10 mA

002 = current output 0...20 mA (i.a. 4...20mA)

003 = voltage output 0...500 mV

004 = voltage output 0...1 V (i.a. 0.2...1 V)

005 = voltage output 0...5 V

006 = voltage output 0...10 V

3.4 rEP - Response time setting.

If the selected response time < 0.06 s, the response time will be 0.06 seconds plus the input frequency response time. The response time will also act on the digital output so that the output will not activate / deactivate because of short-lived changes in the input frequency.

Entering of example = 02.5.

Valid selections are 0.06...999 seconds.

4.0 dOU - Digital setting of output

4.1 dLO - Setting of setpoint / limit frequency in % of the frequency span.

This value corresponds to the setpoint, when menu 4.4 dOA = { InC or dEC }, and it corresponds to the low limit frequency of a setpoint window when menu 4.4 dOA = { UOn or UOF }.

Entering of example = 7.97 (1000 / 12550.5 * 100 [%]).

Valid selections are 0.0...99.9%.

4.2 dHI - setting of limit frequency in % of the frequency span.

This value corresponds to the high limit frequency of a setpoint window and is only valid when menu 4.4 dOA = { UOn or UOF }.

Entering of example = 87.6 (11000 / 12550.5 * 100 [%]).

Valid selections are 0.0...99.9%.

4.3 HYS - Setting of hysteresis in % of the frequency span.

If 4.4 dOA = { UOn or UOF } the hysteresis is outside the window (4.1 and 4.2)

If 4.4 dOA = { InC } the hysteresis is below setpoint (4.1).

If 4.4 dOA = { dEC } the hysteresis is above setpoint (4.1).

Entering of example = 0.16 (20 / 12550.5 * 100 [%]).

Valid selections are 0.0...99.9%.

4.4 dOA - Digital output action setting.

For InC or dEC the digital output action will respectively be increasing or decreasing. The setpoint and the hysteresis must be set in menu 4.1 and 4.3.

For UOn the digital output is activated within the window.

For UOF the digital output is activated outside the window.

The low and the high limit frequency in the window are set in menu 4.1 and 4.2 respectively, and the hysteresis is set in menu 4.3.

Entering of example = UOn.

Possible selections are InC, dEC, UOn or UOF.

4.5 dOF - Digital output function setting.

If L (Limit) is selected, the digital output will work as a trip amplifier.

If LC (Limit, Cable) is selected, the digital output will act as both a trip amplifier and as a sensor error monitor. If C (Cable) is selected, the digital output will act as a sensor error monitor.

Sensor error monitoring is performed only by NAMUR sensor when submenu 5.2 InP = nUr

Entering of example = LC.

Possible selections are L, LC or C.

5.0 APP - Application selection

5.1 FUn - Funktion selection.

On a function change, the unit resets and the display returns to default, menu 0.0.

Possible functions are:

001 = f/I converter

002 = f/f converter

003 = Frequency generator

Entering of example = 001.

Valid selections are 001, 002 and 003

5.2 InP - Sensor type selection.

PnP = PNP proximity switch open collector or switch to +24 VDC.

nPn = NPN proximity switch open collector or switch to Gnd.

ttl = TTL, standard TTL signals at 5 VDC level.

nUr = NAMUR in accordance with DIN 19234.

S0 = S0 interface in accordance with DIN 43864.

tAC = AC Tacho.

Entering of example = nUr.

Possible selections are: PnP, nPn, ttl, nUr, S0 and tAC

5.3 FLt - Input filter setting.

On contact input the LO filter should be used to eliminate bounce input.

Entering of example = Hi.

Possible selections are LO - 50 Hz or HI - 20 kHz.

5.4 PAS - Password selection.

When the password is 040, changes may be made in all menu points. When the password is <> 040, programming is locked in all menu points, but open for reading the value.

Entering of example = 040.

Valid selections are 0...999.

5.5 PUd - Power-up delay setting.

The power-up delay time is the period of time in which the digital output is out of function after power connection.

Entering of example = 10.0.

Valid selections are 0...999 seconds.

Routing diagram

for

f / f converter to multiplication / division [Function no. 002]

Power On At power ON, or if no keys have been activated for a period of 2 minutes, the display returns to main menu 0.0

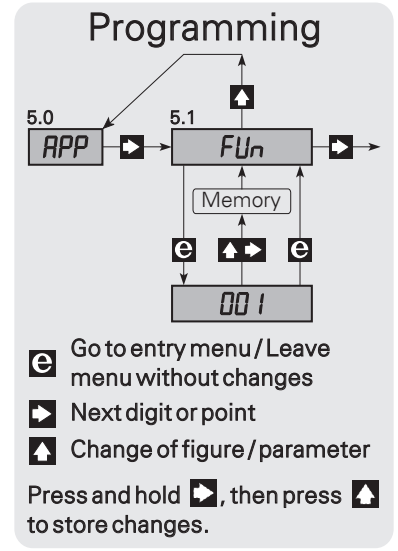
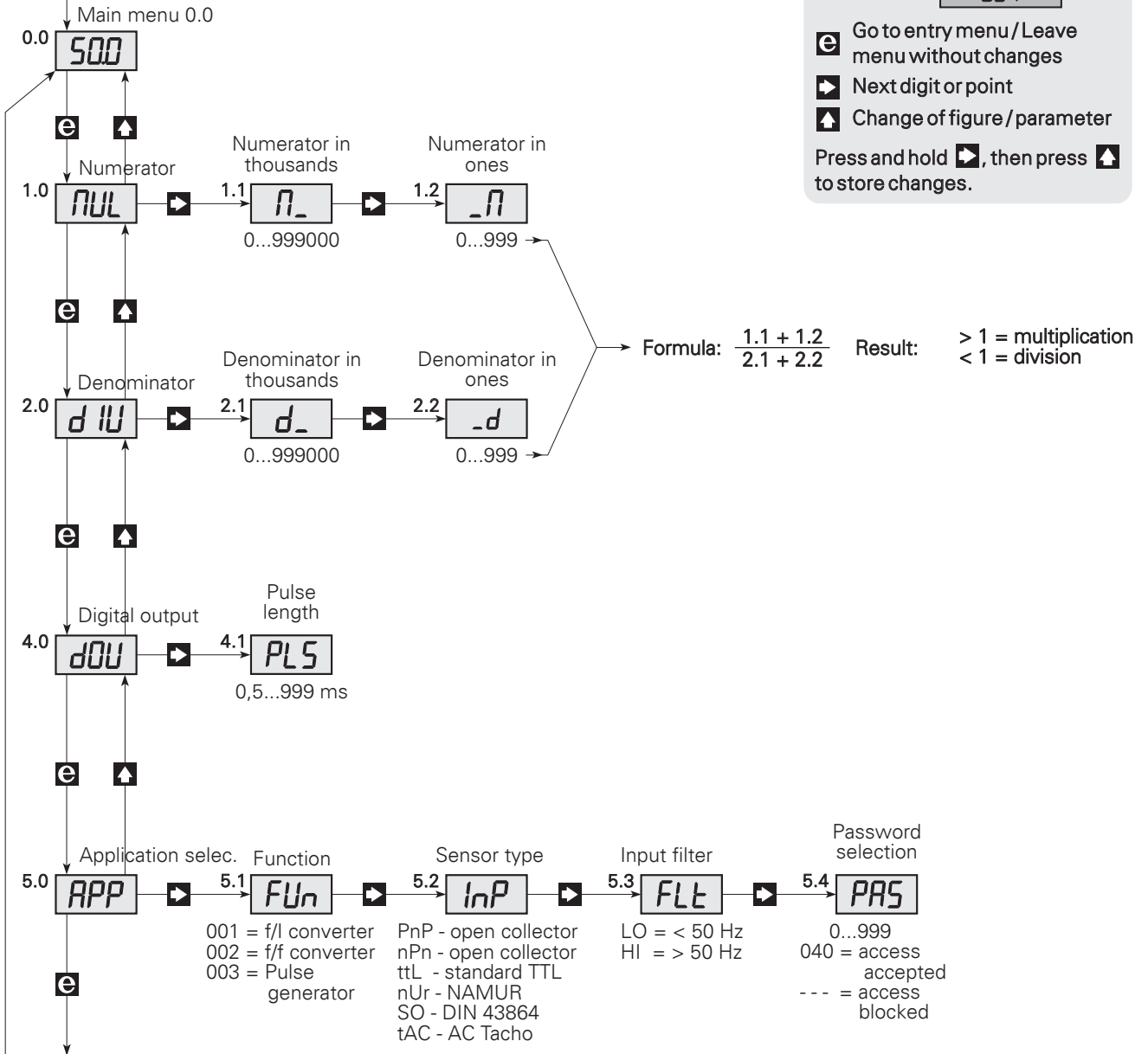

Setting of f/f converter to pulse division / multiplication

The following describes the routing diagram menu points from 0.0 to 5.4 for setting the f/f converter. When the function is selected for f/f converter, the analogue output is disabled so that it assumes the value 0 mA.

Example:

Sensor	NAMUR
Output frequency	Input frequency divided by 6.75
Output pulse length	500 ms

First, the function f/f converter must be chosen in submenu 5.1.

0.0 Default - The number of pulses in the buffer is displayed.

The display returns to default when power is switched ON, or if no keys are activated for a period of 2 minutes. The pulse function is set as a fraction. The numerator is set in submenu 1.1 and 1.2, and the denominator is set in submenu 2.1 and 2.2. If for instance the input frequency must be multiplied by 10 the multiplier is set to 10 and the divisor is set to 1.

1.0 MUL - Setting the multiplier.

In submenu 1.1 og 1.2 the numerator is set to a value between 0 and 999999.

1.1 M- - Setting of multiplier in thousands.

Entering of example = 000
Valid selections are 0...999000

1.2 -M - Setting of multiplier in ones.

Entering of example = 100
Valid selections are 0...999

2.0 dIV - Setting the divisor.

In submenu 2.1 and 2.2 the denominator is set to a value between 0 and 999999.

2.1 d- - Setting of divisor in thousands.

Entering of example = 000
Valid selections are 0...999000

2.2 -d - Setting of divisor in ones.

Entering of example = 675
Valid selections are 0...999

4.0 dOU - Output pulse length setting

4.1 PLS - Setting of output pulse length in ms.

Entering of example = 500
Valid selections are 0.5...999 ms (max. 1000 Hz)

5.0 APP - Application selection.

5.1 FUn - Function selection.

On a function change, the unit resets and the display returns to default, menu 0.0.

Entering of example = 002
Possible selections are:

001 = f/I converter

002 = f/f converter

003 = Frequency generator

5.2 InP - Sensor type selection.

Entering of example = nUr

Possible selections are:

PnP = PNP proximity switch open collector or switch to +24 VDC.

nPn = NPN proximity switch open collector or switch to Gnd.

ttl = TTL, standard TTL signals on 5 VDC level.

nUr = NAMUR in accordance with DIN 19234.

S0 = S0 interface in accordance with DIN 43864.

tAC = AC Tacho.

5.3 FLt - Input filter setting.

LO filter should be used on the switch input to eliminate bounce.

Entering of example = HI

Possible selections are LO - 50Hz or HI - 20kHz.

5.4 PAS - Password selection.

When the password is 040, changes may be made in all menu points.

When the password is <> 040, programming is blocked in all menu points but open for reading the setting value.

Entering of example = 040.

Valid selections are 0...999.

Routing diagram

for

Frequency generator [Function no. 003]

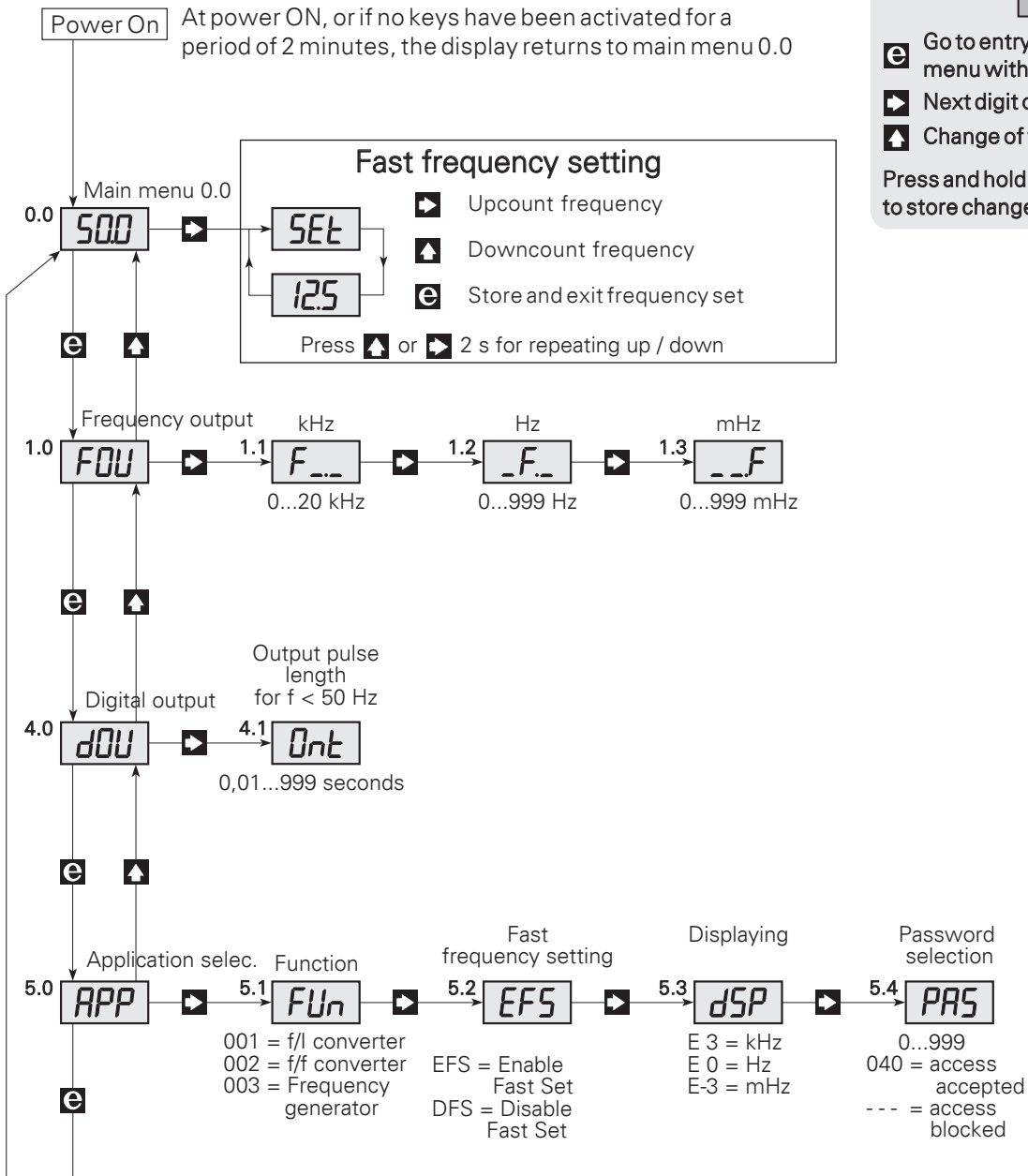

Programming

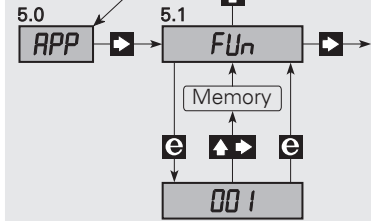

- e Go to entry menu / Leave menu without changes
 - ▶ Next digit or point
 - ▲ Change of figure / parameter
- Press and hold ▶, then press ▲ to store changes.

Setting of frequency generator

The following describes the routing diagram menu points from 0.0 to 5.4 for setting as a frequency generator. When the function is selected as a frequency generator, the analogue output is disabled.

Example:

Output frequency	12550.5 Hz
Fast change of frequency	Possible
Displaying	in kHz



First, the function frequency generator must be chosen in submenu 5.1.

0.0 Default - The output frequency in kHz, Hz or mHz is displayed.

The display returns to default when power is switched ON, or if no keys are pressed for a period of 2 minutes. Pressing  will indicate the present function, i.a. F01.

Fast setting - Shortcut key for changing output frequency

When submenu 5.2 has been selected for EFS - Enable Fast Setting -, fast frequency changing is possible with the Fast Setting function.

The function keys in this menu have a special function:  counts the frequency up and  counts the frequency down from the value it had when activated.  stores the value; the output changes to the frequency displayed.

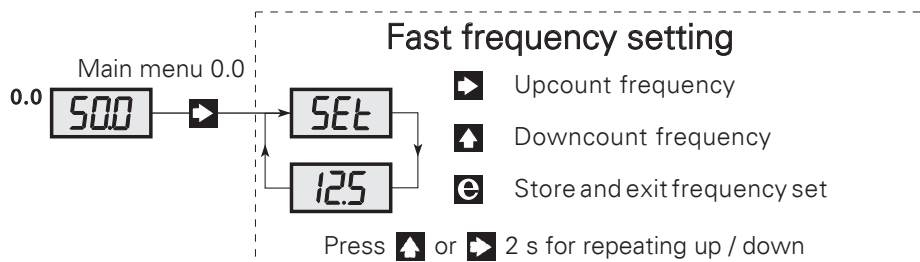

1.0 F0U - Output frequency setting

1.1 F.- - Setting of output frequency in kHz.

Entering of example = 012.
Valid selections are 0...20.0 kHz.

1.2 -F.- - Setting of output frequency in Hz.

Entering of example = 550.
Valid selections are 0...999 Hz.

1.3 -.F - Setting of output frequency in mHz.

Entering of example = 500.
Valid selections are 0...999 mHz.

4.0 d0U - Output pulse length setting

4.1 Ont - Setting of output pulse length in s.

The pulse length can only be set for frequencies < 50 Hz, and an interval of minimum 10 ms between the pulses is always required. At frequencies of 50 Hz and above, the pulses have a 50% duty cycle.
Entering of example = 500.
Valid selections are 0.01...999 s.

5.0 APP - Application selection.

5.1 FUn - Function selection

On function change, the unit resets and the display returns to default, menu 0.0

Entering of example = 003

Possible selections are:

001 = f/l converter

002 = f/f converter

003 = Frequency generator.

5.2 EFS - Access setting for fast frequency changing.

Access to fast frequency changing is determined by the parameters EFS - Enable Fast setting, or dFS - Disable Fast setting.

Entering of example = EFS

Possible selections are EFS or dFS.

5.3 dSP - Default display units.

Entering of example = E 3

Possible selections are E 3 display in kHz, E 0 display in Hz or E-3 display in mHz.

5.4 PAS - Password selection.

When the password is 040, changes may be made in all menu points. When the password is <> 040, the programming is blocked in all menu points but open for reading the value.

Entering of example = 040.

Valid selections are 0...999.

Document history

The following list provides notes concerning revisions of this document.

Rev. ID	Date	Notes
103	2232	Relay data updated, graph with resistive loads inserted. UKCA added.

We are near you, *all over the world*

Our trusted red boxes are supported wherever you are

All our devices are backed by expert service and a 5-year warranty. With each product you purchase, you receive personal technical support and guidance, day-to-day delivery, repair without charge within the warranty period and easily accessible documentation.

We are headquartered in Denmark, and have offices and authorized partners the world over. We are a local

business with a global reach. This means that we are always nearby and know your local markets well. We are committed to your satisfaction and provide PERFORMANCE MADE SMARTER all around the world.

For more information on our warranty program, or to meet with a sales representative in your region, visit prelectronics.com.

Benefit today from *PERFORMANCE MADE SMARTER*

PR electronics is the leading technology company specialized in making industrial process control safer, more reliable and more efficient. Since 1974, we have been dedicated to perfecting our core competence of innovating high precision technology with low power consumption. This dedication continues to set new standards for products communicating, monitoring and connecting our customers' process measurement points to their process control systems.

Our innovative, patented technologies are derived from our extensive R&D facilities and from having a great understanding of our customers' needs and processes. We are guided by principles of simplicity, focus, courage and excellence, enabling some of the world's greatest companies to achieve PERFORMANCE MADE SMARTER.